

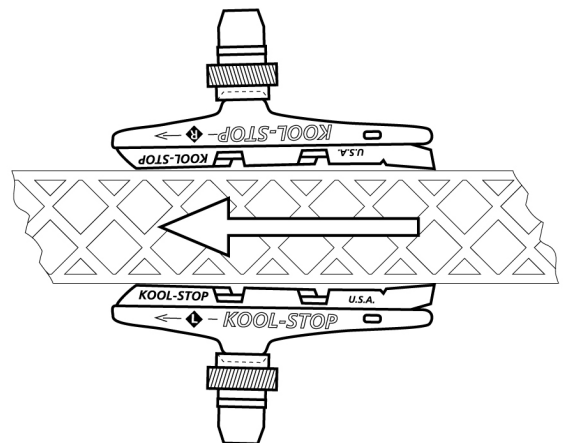

INSTALLATION INSTRUCTIONS

V-BRAKE THREADED

- H4 Tectonic
- H5 V-Brake
- H7 Cross Holder (R4 +R7)

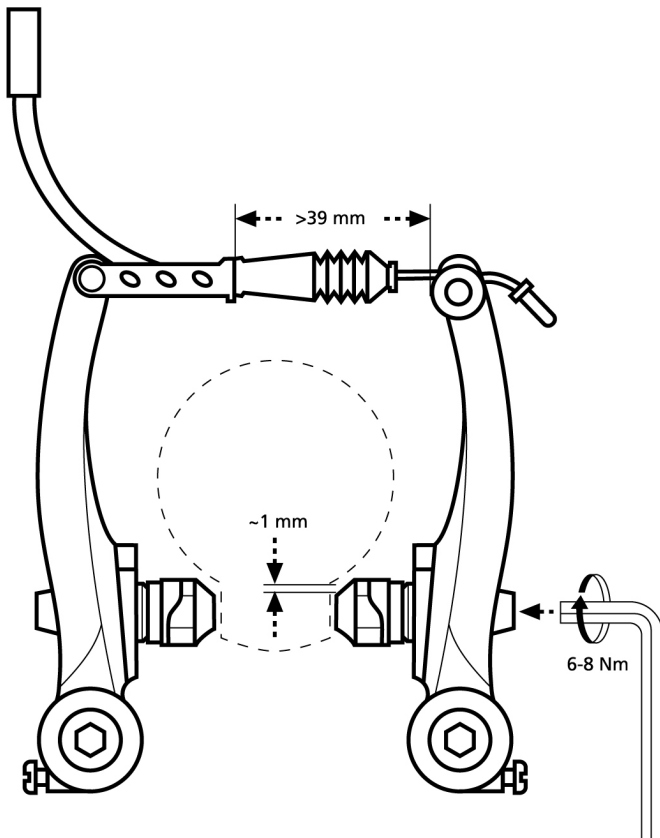
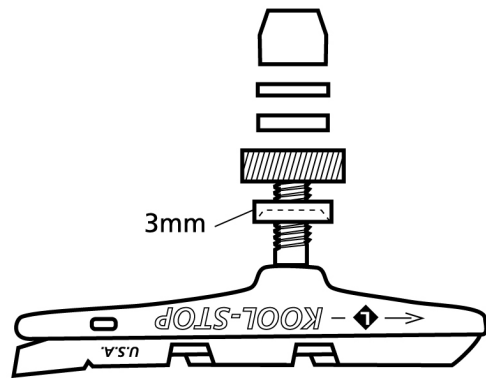
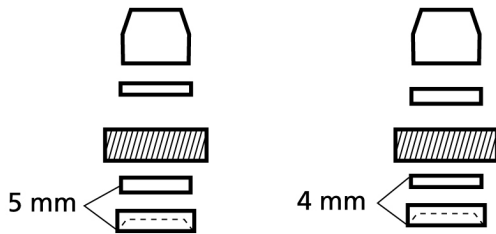

- Clean rim surface before installing new pads.
- Place new pads and finger tighten nuts.
- Align the pads correctly without touching the tire.
- Now tighten the nut with a force of 6-8 Nm.
- Check pad and rim alignment after the pads are broken in and after every ride.

IMPORTANT: Designed for bicycle use only. Do not ride bike until brakes are checked and functioning properly. All Kool-Stop Pads meet or exceed C.P.S.C. and D.I.N bicycle standards.